



**PRESSURE SWITCHES
PRESSURE DIFFERENCE SWITCHES
VACUUM SWITCHES**
From 1.5 mbar to 600 bar

DP Pressure Switches

INSTALLATION AND OPERATING INSTRUCTIONS



Kaustubha Udyog (Orion Instruments)

S. No. 36/1/1, Sinhgad Road, Vadgaon Khurd, Pune 411 041 INDIA
Tel.: +91-(0) 20-24393877 / 24351592
Telefax : +91-(0) 20-24393577 / 25460486
Email : ku.pressure@gmail.com

Certificate No.: FM72815



Website : www.orion-instruments.io

INSTALLATION AND OPERATING INSTRUCTIONS FOR DP PRESSURE SWITCHES

Construction

The pressure switch is housed in a die-cast aluminum enclosure which conforms to IP54 protection factor. For calibrated models a scale, visible through a window, is provided. The pressure capsules, comprise a pressure housing (either of aluminum, brass or SS316), a disc, nylon reinforced rubber diaphragm and a plunger. The electrical changeovers is through a snap action microswitch. The electrical wiring terminates at a terminal strip having screwed ends. A 3/8" cable gland has been provided for cable entry.

Principle of Operation

The pressure in the high pressure capsule is converted into force by means of a reinforced rubber diaphragm and calibrated pistons, which is balanced by a compression spring and the force generated in the low pressure capsule above. When the force generated in the high pressure capsule exceeds/falls beyond the balancing spring force and the force generated in the low pressure capsule, an electrical element is actuated.

NOTE : DP models can be used to sense difference between two POSITIVE PRESSURES ONLY.

Mounting

Please refer Fig. 1.1

The pressure difference switches can be mounted in any direction.

- 1) For high range pressure switches :
 - a) Pressure switches can be mounted directly in case the mounting is rigid.
 - b) For panel mounting, use M5 bolts of appropriate length through the mounting holes. If the equipment is subject to vibration, please use rubber washers / pads between the panel and the switch.
- 2) Connect the pressure tubing to the pressure ports. The pressure port size is generally 1/4" B.S.P. female, unless specially ordered otherwise. Other sizes can be obtained via adaptors.

Fig 1.1

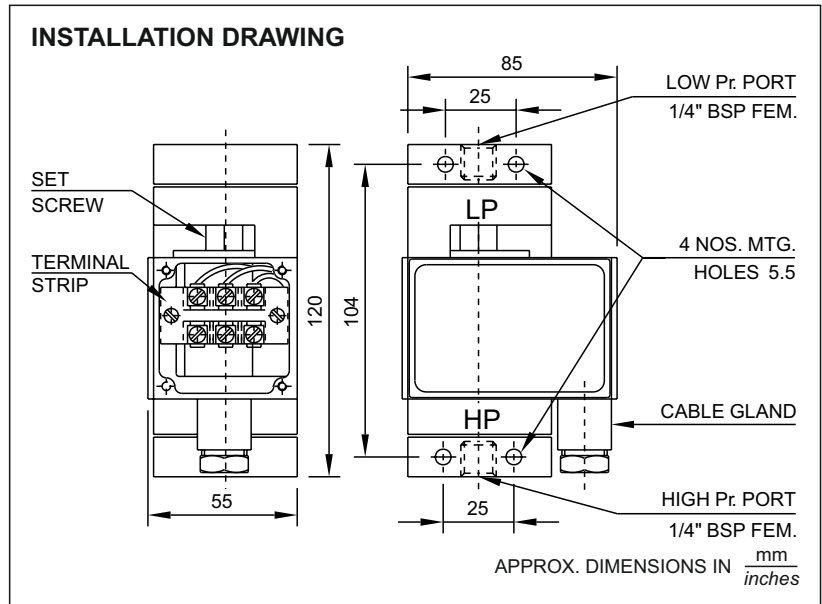

Electrical Connections

Pressure difference switches will generally have only one SPDT microswitch. Pressure difference switches with two SPDT microswitches can also be provided, with preset stage differentials.

Wiring

Fig. 1.2

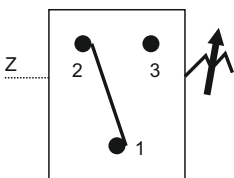

Please refer Fig. 1.3

- a) Remove the right hand side (RHS) cover.
- b) Pass the cable through the cable gland and connect the wiring as per the wiring diagram.

The colour code is as per the details given below.

- terminal 1 (common) : Red
- terminal 2 (Normally closed) : Black
- terminal 3 (Normally open) : Yellow

Set Point Adjustment

Please refer Fig. 1.3

- 1) Use a spanner of size 13 to adjust the setpoint of the pressure difference switch. The setscrew is located under the low pressure capsule as indicated in figure 1.1.
- 2)
 - i) For DP uncalibrated models. 2.1 turn the setscrew to the extreme negative end.
 - ii) For DP calibrated models 2.1 Adjust the desired setpoint on the scale.
- 3) Apply the desired HP (high pressure) / LP (Low pressure) pressure to the high and low pressure capsules of the pressure difference switch.
- 4)
 - i) For DP uncalibrated Models. 4.1 Increase the pressure setting by turning the set screw till contacts changeover.
 - ii) For DP calibrated models 4.1 proceed to Step 5
- 5) Some minor adjustment will be required to achieve the exact cut in (lower) / cutout (higher) point, which can be checked with the help of a proper pressure measurement device.

Tip : The pressure difference switches are generally factory set at half the setpoint range (unless otherwise specified in a Purchase Order). Step 2 can be omitted if the desired set point is more than the factory setting.

Trouble Shooting Tips

Generally no problems are observed if the pressure switch selection, wiring and the setpoint is proper. For a pressure switch selection procedure, please consult our sales office. For properly selected pressure switches, if following symptoms are observed, the likely causes and remedies are as stated

Symptom 1: Switch does not operate

Please refer Fig. 1.4

- 1) Wiring may not be correct. Check electrical connections to the pressure switch, if they are as per the wiring diagram.
- 2) Pressure does not reach the pressure port.
 - a) Check if the entry to the pressure capsule is not blocked by frozen process or scales or impurities in the process.

DO NOT OPEN THE PRESSURE CAPSULE IN ANY EVENT

- 3) Check if the high pressure side is connected to the high pressure port and low pressure side is connected to the low pressure port.

If the cause is none of the above mentioned probabilities, proceed as per the following steps.

- a) Check the system pressure & set point of pressure switch.
 - i) For use of pressure switch for falling setpoints, system pressure difference has to be greater than cutout point.

Fig 1.3

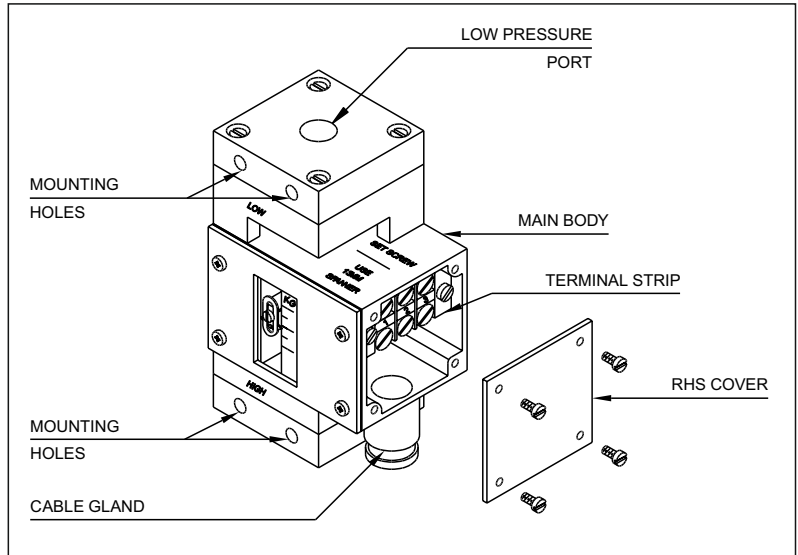
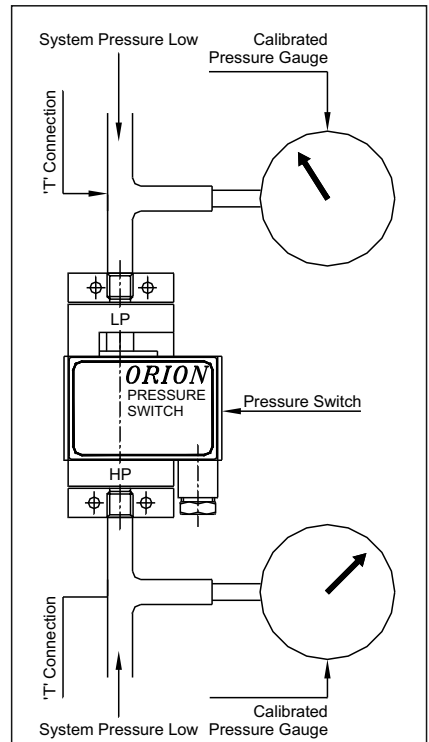

Fig 1.4



- ii) For use of pressure switch for rising setpoints, the system pressure difference may not be reaching / exceeding the cutout point.
- b) Use 'T' connection & connect calibrated pressure gauges to the 'T' connection as shown in the figure 1.4.
- c) Adjust the setpoint such that the system pressure difference is greater than the cut-out point of the pressure switch.
- d) If the switch still does not operate, remove the pressure switch physically from the system. There should be continuity between terminals 1 & 2. If no continuity is observed, the pressure switch should be returned to the factory.

Symptom 2 : Short Wiring

Isolate the switch electrically. Check the continuity between terminals and the screws fitted to the body. If no continuity is observed in between any of the terminals and screws fitted to the body, check the short connection elsewhere in the circuit. If continuity is observed, the wires of the pressure switch have internally touched the body, and the switch should be returned to the factory.

Symptom 3 : Leakage

In case leakage is observed, the pressure switch has to be returned to the factory without opening the pressure capsule. Check for the following likely causes and use a new switch taking proper precautions.

- a) System pressure is greater than specified maximum working pressure : Use an overrange protector or a switch with appropriate maximum working pressure.
- b) Incompatible wetted parts : The working medium may not be compatible with wetted parts, which damages the sealing of the process from working parts. Use a chemical seal for the pressure switch or use proper compatible wetted parts.
- c) Excessive process temperature : Process temperature may exceed maximum allowable temperature, which in turn damages the diaphragms. Use an impulse tubing of proper length for cooling the process temperature. There may be pressure drop depending on length of the impulse tube used. Adjust the setpoint of the pressure switch accordingly.

Symptom 4 : Chattering

- 1) Check the system pressure for surges. Chattering is observed where the system pressure is close to the cutin/cutout point and the surge pressure exceeds the on-off differential. Use a pressure switch with an adjustable differential or use surge dampers in your system. An impulse tube may also be of help if the surges are not very large. ■